

Project:

Leeds College of Technology

Client: McAleer & Rushe

Designer: David Lyons Associates

Location: Leeds

Programme: 6 Weeks

Sector: Student Accommodation

Project Value: £200k

Hurst
Joinery Projects

Contact

info@hurstjoineryprojects.co.uk

www.hurstjoineryprojects.co.uk

01274 711260





Brief

Hurst Joinery Projects was appointed by McAleer & Rushe to supply bespoke joinery for the Leeds College of Technology Campus redevelopment. This project involved a 19-storey student accommodation tower comprising 514 units, with additional ground floor amenity spaces.

Located in the heart of Leeds' university area, the development aimed to enhance student living and contribute to the city's regeneration.

Hurst secured the contract due to its extensive experience in student accommodation amenity schemes. Our ability to contribute to the design process, proximity to the site, and strong track record in the sector, made us a trusted choice.

Result

Hurst successfully delivered precise joinery solutions for Leeds College of Technology Campus, meeting both the project's high standards and the client's specifications for seating, planters, tea points, café areas, gym mirrors, reception areas, and more. The team played a significant role in designing these elements, ensuring they aligned with the client's vision.

Close collaboration with the team enabled the project to be completed on time and within budget, enhancing the functional and aesthetic aspects of the communal spaces while adhering to safety standards.

Items Produced

- Reception desk with canopy, illuminated sign and shutters
- Tea points in management, café and communal areas
- Backlit gym mirrors
- Bespoke Planters
- High seating with integrated planter
- Folding benches for launderette
- Upholstered booth and banquette seating to café, games room and waiting areas
- Class A fire-rated Zintra acoustic wall panelling
- ORAC wall cladding to meeting room
- Open shelving for deliveries
- Fifty-six suspended acoustic ceiling baffles
- Karaoke painted feature wall panels





Challenges

Whilst the client had a desired look and feel for the project, the joinery elements required designing to meet their vision. As part of our services our experienced setting out team played a crucial role in this process, taking the lead in designing the features based on the client's input.

By working closely with the client, we gained a thorough understanding of their requirements, ensuring that our designs aligned with their budget and timeline. This collaborative approach allowed us to deliver tailored solutions that met both aesthetic and functional needs.

Solution

The project included the supply and installation of various quality bespoke joinery elements such as seating, planters, tea points, café areas, gym mirrors, and the reception area, complete with a desk and canopy.

Additional contributions included signage, fire-rated panelling and ceiling features, all of which were developed to meet the practical and design needs of the spaces while adhering to safety requirements.



“From early design conception to final installation, Hurst Joinery Projects were highly professional and brought knowledge to the project for the bespoke joinery. During the design development process, the team worked closely with ourselves and design consultants to develop a high quality product for the client which aided in the success of presenting great amenity spaces for the students and staff. We look forward to continuing the working relationship on future schemes”

David Ward

Project Manager, McAleer & Rushe



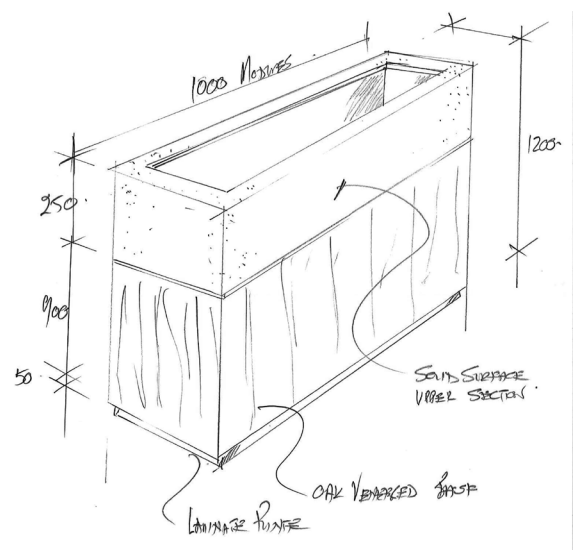
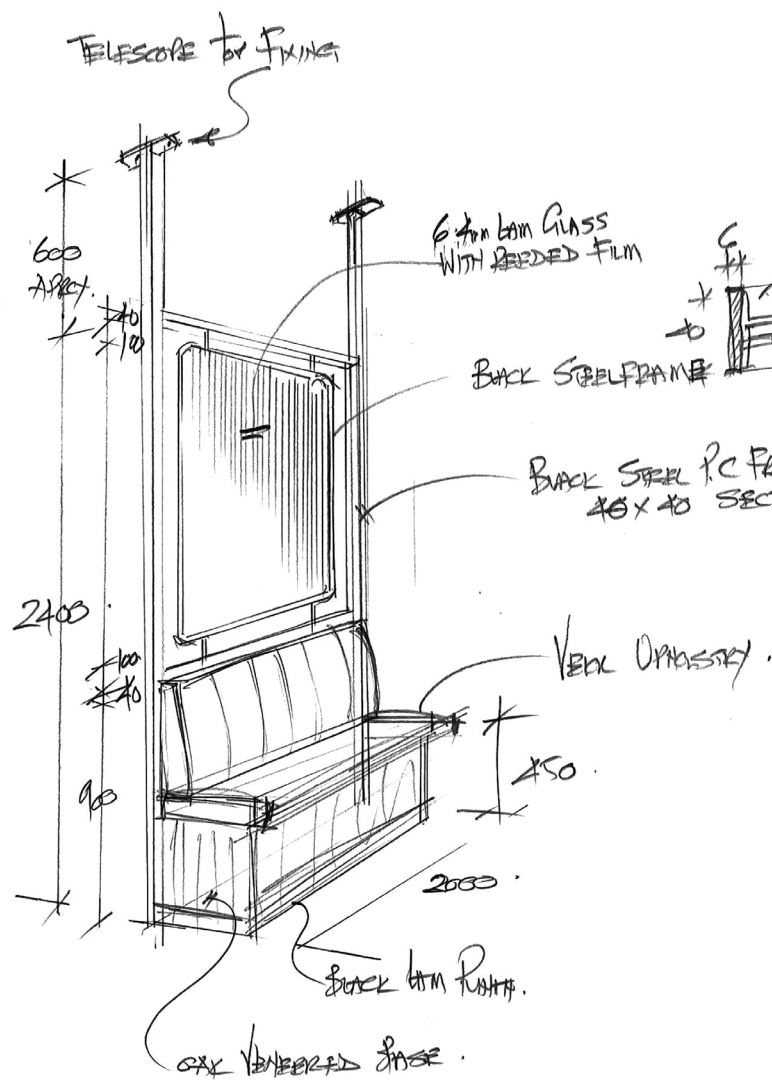

To view further case studies visit
hurstjoineryprojects.co.uk/projects

Contact

Head office: 01274 711260
London Office: 07794 078830
[**info@hurstjoineryprojects.co.uk**](mailto:info@hurstjoineryprojects.co.uk)
[**www.hurstjoineryprojects.co.uk**](http://www.hurstjoineryprojects.co.uk)

Aynsley House
Common Road
Low Moor, Bradford
West Yorkshire
BD12 0UF